

Motor Moteur		kW
n=		min ⁻¹
x=		mm
Øy=		mm
z=		mm
e=		mm
p=		mm
ØA=		mm
ØB=		mm
ØC=		mm

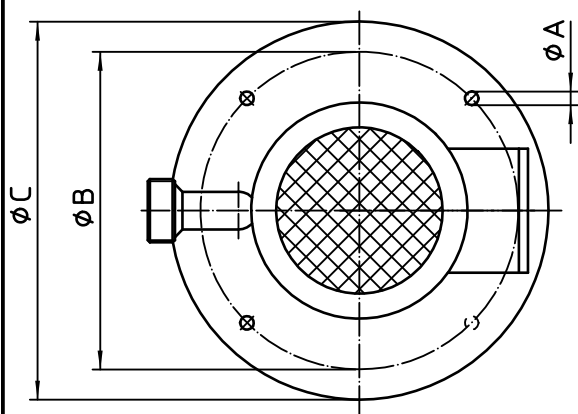

Einbaumaße:
Mounting dimensions:
Dimensions de montage:

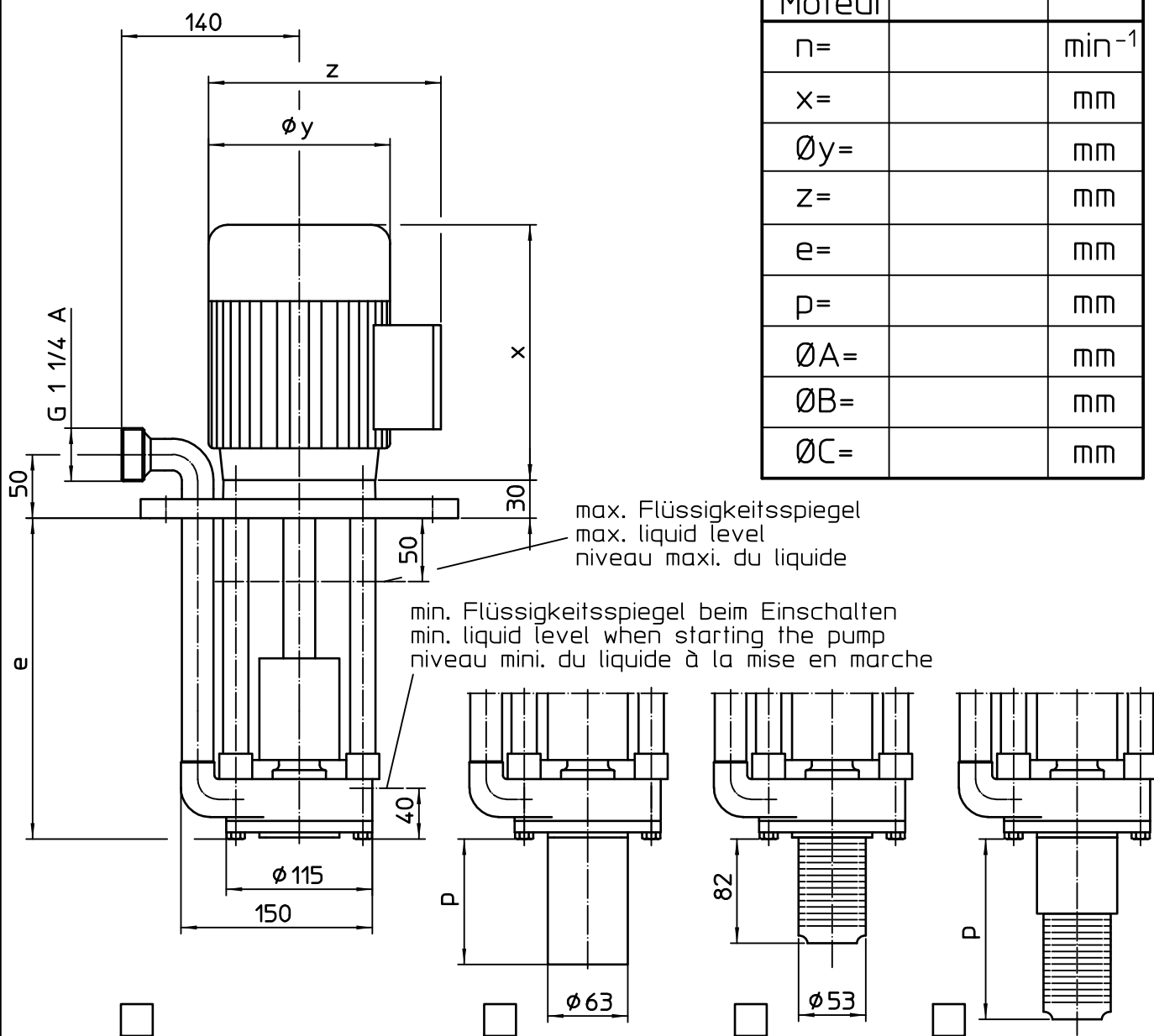