

Aquaplus

ESDM Series
End Suction DIN
Bare Shaft Pumps



DIN Bare Shaft Pumps

**2 Year
Warranty!**

*Extensive stock holdings
Australia-wide*

Manufactured to the DIN24255
(EN733) standard

www.aquapluspumps.com.au

The ESDM Series Bareshaft Pumps are robust and reliable DIN pumps, ideal for your building services, irrigation, fire systems and mining applications. The DIN pump range is also available in Motor Pumps and Long Coupled configurations.

Features

- Extensive stock holdings Australia-wide
- Dynamically balanced impeller
- Double shrouded impeller design
- Back pull-out facility
- Maximum operating pressure 1600kPa dependent on pump model
- Maximum speed varies between 1500 RPM and 3600 RPM dependant on pump size and method of drive
- Maximum temperature with standard mechanical seal shaft sealing arrangement -10°C to 120°C
- Cast metal casing with integrally cast feet
- Re-usable casing o-rings
- Shaft carried in grease lubricated bearings (oil lubrication available on request)
- Cast iron bearing housing

Features (cont.)

- Shaft sealing is standard as mechanical seal with stainless steel shaft sleeve (packed gland available on request)
- Replaceable wear rings fitted to all volutes
- Removable support foot at drive end for greater rigidity
- Pumps manufactured to the German Standard DIN24255 (EN733)

Applications

- Building Services: condenser water, heating water, chilled water
- Mining: transfer and processing applications
- Irrigation
- Commercial swimming pools
- Fire protection

Cutaway

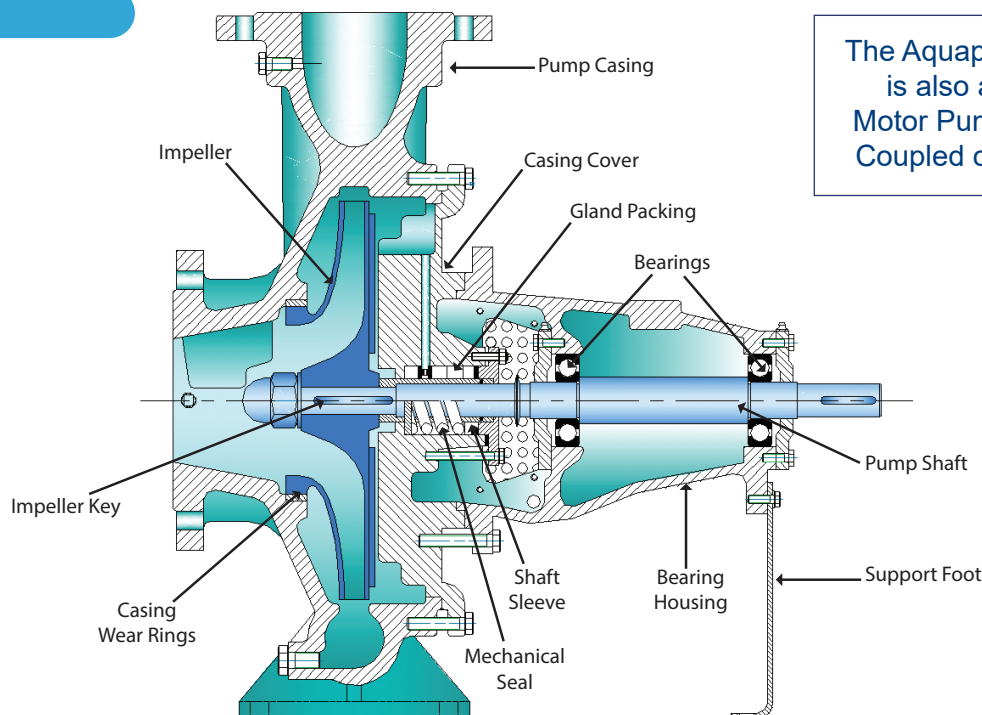

The Aquaplus DIN range is also available in Motor Pumps and Long Coupled configurations

Pump Material Options*

Code	Casing	Impeller	Shaft	Shaft Sleeve	Wear Ring
10	Cast iron AS1830 T220	Bronze (Zinc free) AS1565 C95210	Stainless steel AS1449 GR420	Stainless steel AS1449 316Ti	Bronze (Zinc free) AS1830 T220
50	Cast iron AS1830 T220	Stainless steel AS1449 316Ti	Stainless steel AS1449 GR420	Stainless steel AS1449 316Ti	Cast iron AS1830 T220
52	Cast iron AS1830 T220	Cast iron AS1830 T220	Stainless steel AS1449 GR420	Stainless steel AS1449 316Ti	Cast iron AS1830 T220

*All materials are solid cast, with no body filler, ensuring lasting performance quality.

All content is subject to change without notice.

Pump Dimensions

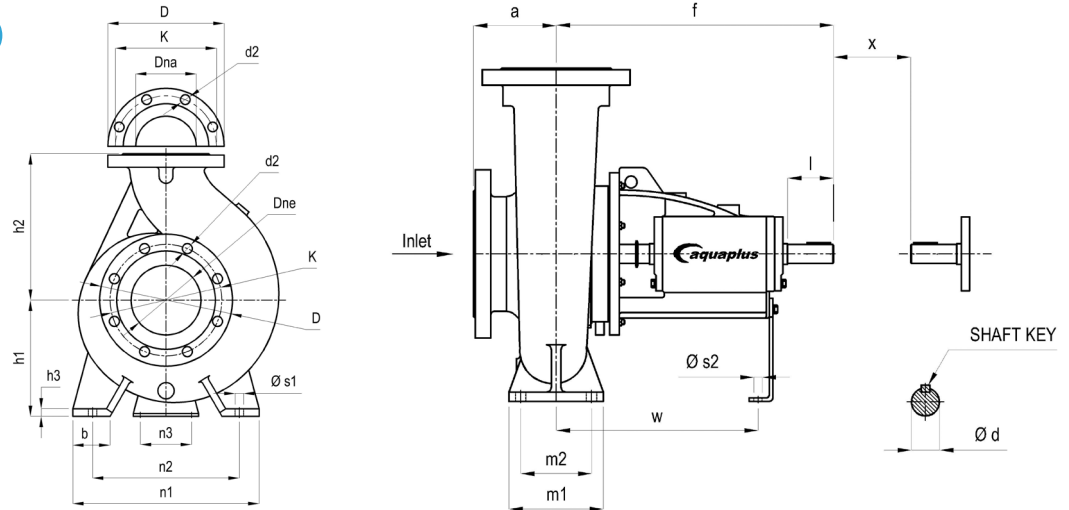

Pump Size (mm)	Frame (mm)	Suct. (mm)	Disch (mm)	Pump (mm)				Foot (mm)							Shaft End (mm)			Shaft Key (mm)	Spacer Length X (mm)	Pump Weight (kg)		
				a	f	h1	h2	b	m1	m2	n1	n2	n3	h3	s1	s2	w				d	l
32-130	25	50	32	80	360	112	140	50	100	70	190	140	100	14	14	14	267	24	49	8x7x32	100	27
32-160	25	50	32	80	360	132	160	50	100	70	240	190	100	14	14	14	267	24	49	8x7x32	100	35
32-200	25	50	32	80	360	160	180	50	100	70	240	190	110	14	14	14	267	24	49	8x7x32	100	41
*32-260	25	50	32	100	360	180	225	65	125	95	320	250	110	14	14	14	267	24	49	8x7x32	100	59
40-130	25	65	40	80	360	112	140	50	100	70	210	160	100	14	14	14	267	24	49	8x7x32	100	30
40-160	25	65	40	80	360	132	160	50	100	70	240	190	100	14	14	14	267	24	49	8x7x32	100	41.8
40-200	25	65	40	100	360	160	180	50	100	70	265	212	110	16	14	14	267	24	49	8x7x32	100	49
40-260	25	65	40	100	360	180	225	65	125	95	320	250	110	14	14	14	267	24	49	8x7x32	100	66.5
*40-320	35	65	40	125	470	200	250	65	125	95	345	280	110	16	14	14	342	32	78	10x8x40	140	96
*40-320H	35	65	40	125	470	200	250	65	125	95	345	280	110	16	14	14	342	32	78	10x8x40	140	96
50-130	25	65	50	100	360	132	160	50	100	70	240	190	100	14	14	14	267	24	49	8x7x32	100	34
50-160	25	65	50	100	360	160	180	50	100	70	265	212	110	14	14	14	267	24	49	8x7x32	100	38
50-200	25	65	50	100	360	160	200	50	100	70	265	212	110	14	14	14	267	24	49	8x7x32	100	50.5
50-260	25	65	50	100	360	180	225	65	125	95	320	250	110	14	14	14	267	24	49	8x7x32	100	63
*50-320	35	65	50	125	470	225	280	65	125	95	345	280	110	16	14	14	342	32	78	10x8x40	140	101
*50-320H	35H	65	50	125	470	225	280	65	125	95	345	280	110	16	14	14	342	32	78	10x8x40	140	101
65-130	25	80	65	100	360	160	180	65	125	95	280	212	110	15	14	14	267	24	49	8x7x32	100	39
65-160	25	80	65	100	360	160	200	65	125	95	280	212	110	16	14	14	267	24	49	8x7x32	100	43
65-200	25	80	65	100	360	180	225	65	125	95	320	250	110	14	14	14	267	24	49	8x7x32	100	70
65-260	35	80	65	100	470	200	250	80	160	120	360	280	110	15	18	14	342	32	78	10x8x40	100	84
65-320	35	80	65	125	465	225	280	80	160	120	400	315	110	16	18	14	337	32	78	10x8x40	140	110
65-320H	35H	80	65	125	465	225	280	80	160	120	400	315	110	16	18	14	337	32	78	10x8x40	140	110
80-160	25	100	80	125	360	180	225	65	125	95	320	250	110	16	14	14	267	24	49	8x7x32	140	54
80-200	35	100	80	125	470	180	250	65	125	95	345	280	110	14	14	14	342	32	78	10x8x40	140	70
80-260	35	100	80	125	470	200	280	80	160	120	400	315	110	16	18	14	342	32	78	10x8x40	140	91
80-320	35	100	80	125	470	250	315	80	160	120	400	315	110	18	18	14	342	32	78	10x8x40	140	110.5
80-320H	35H	100	80	125	470	250	315	80	160	120	400	315	110	18	18	14	342	32	78	10x8x40	140	110.5
80-400	45	100	80	125	520	280	355	80	160	120	440	355	110	18	18	14	362	42	110	12x8x56	140	161
*100-160	25	125	100	125	370	180	225	65	125	95	320	250	110	16	14	14	277	24	49	8x7x32	140	71
100-200	35	125	100	125	470	200	280	80	160	120	360	280	110	16	18	14	342	32	78	10x8x40	140	85
100-260	35	125	100	140	470	225	280	80	160	120	400	315	110	16	18	14	342	32	78	10x8x40	140	106
100-320	35	125	100	140	470	250	315	80	160	120	400	315	110	16	18	14	342	32	78	10x8x40	140	111
100-400	45	125	100	140	530	280	355	100	200	150	500	400	110	18	23	14	372	42	110	12x8x56	140	174
*125-200	35	150	125	140	470	250	315	80	160	120	400	315	110	16	18	14	342	32	78	10x8x40	140	106
125-260	35	150	125	140	470	250	355	80	160	120	400	315	110	16	18	14	342	32	78	10x8x40	140	115
125-320	45	150	125	140	530	280	355	100	200	150	500	400	110	18	23	14	372	42	110	12x8x56	140	163
125-400	45	150	125	140	530	315	400	100	200	150	500	400	110	18	23	14	372	42	110	12x8x56	140	181
*150-200	35G	200	150	160	495	280	400	100	200	150	550	450	110	20	23	14	367	32	78	10x8x40	140	156
*150-260	45	200	150	160	528	250	355	100	200	150	450	350	110	18	23	14	370	42	110	12x8x56	140	148
*150-320	45	200	150	160	536	280	400	100	200	150	550	450	110	18	23	14	379	42	110	12x8x56	140	167.5
150-400	45	200	150	160	530	315	450	100	200	150	550	450	110	18	23	14	372	42	110	12x8x56	140	209
*150-500	60	200	150	180	670	375	500	140	200	150	660	550	110	27	23	14	510	55	110	16x10x100	180	320
*200-260	45A	250	200	180	546	280	400	100	200	150	550	450	110	25	23	14	393	48	110	12x8x56	180	206
*200-320	55	250	200	180	670	355	450	100	200	150	550	450	110	20	24	14	511	48	110	14x9x100	180	251
*200-400	55	250	200	200	670	355	500	100	200	150	550	450	110	20	24	14	511	48	110	14x9x100	180	295
*200-500	70	250	200	250	780	400	500	120	300	250	710	600	140	25	23	19	540	65	140	18x11x100	180	410
*250-320	60	300	250	200	670	355	525	100	250	175	600	500	110	25	23	14	510	55	110	16x10x100	180	311
*250-400	70	300	250	250	780	400	500	120	300	250	710	600	140	25	23	19	540	65	140	18x11x100	180	390
*250-500	75	300	250	240	875	425	545	160	300	200	720	600	140	30	27.5	19	625	70	140	20x12x120	180	516
*300-320	75	350	300	260	875	400	562	140	300	200	750	600	140	30	27.5	19	634	70	140	20x12x120	180	660
*300-400	75	350	300	280	875	500	600	150	300	200	800	660	140	40	27.5	23	625	70	140	20x12x120	180	700

* Denotes pump models that are NOT included within the DIN24255 (EN733) pump standard

K	100	110	126	146	160	180	210	240	295	355	410	470
d2 x No	4 x 18	4 x 18	4 x 18	4 x 18	8 x 18	8 x 18	8 x 18	8 x 22	12 x 22	12 x 25	12 x 25	16 x 25
Dna & Dne	32	40	50	65	80	100	125	150	200	250	300	350
D	140	150	165	185	200	220	250	285	340	405	460	520

Flange mating dimensions to ISO2084 PN16 (DIN2533 PN16, BS4504 PN16)
Note: Other flange standards available on request

All content is subject to change without notice.

Performance Curves

2900 RPM
I.G.P.M.

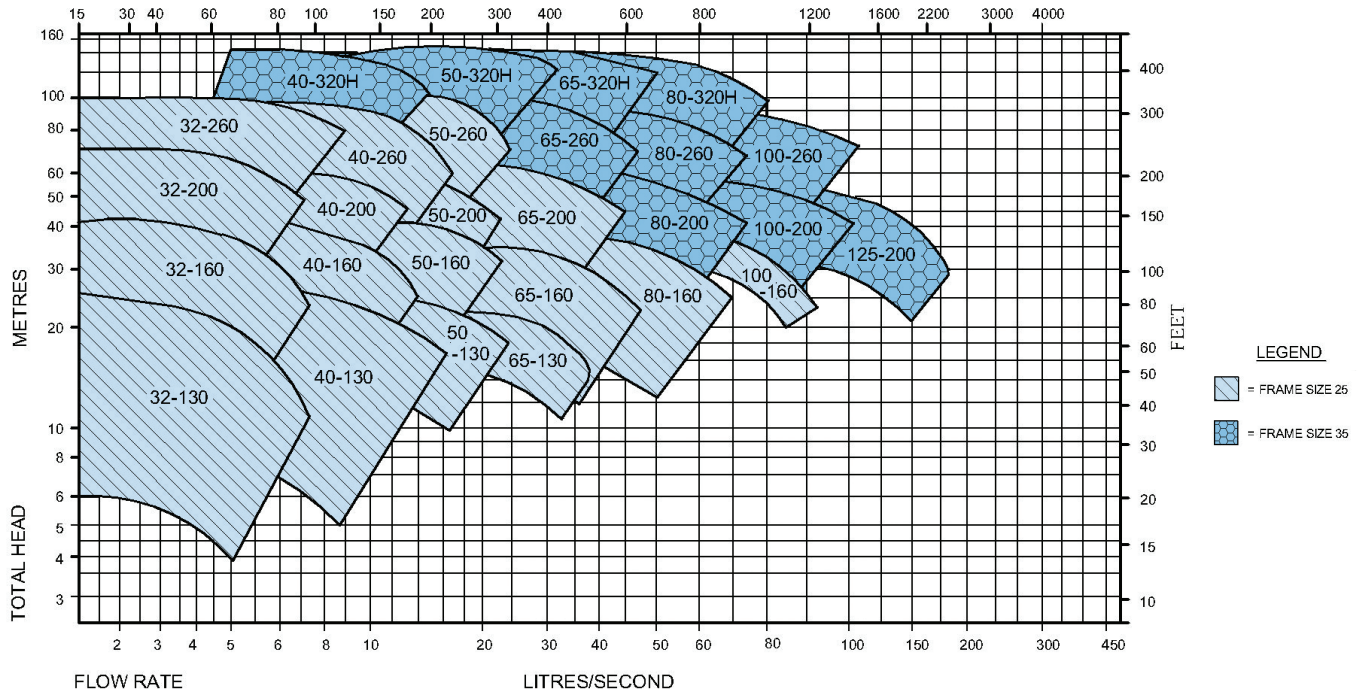

1450 RPM
I.G.P.M.

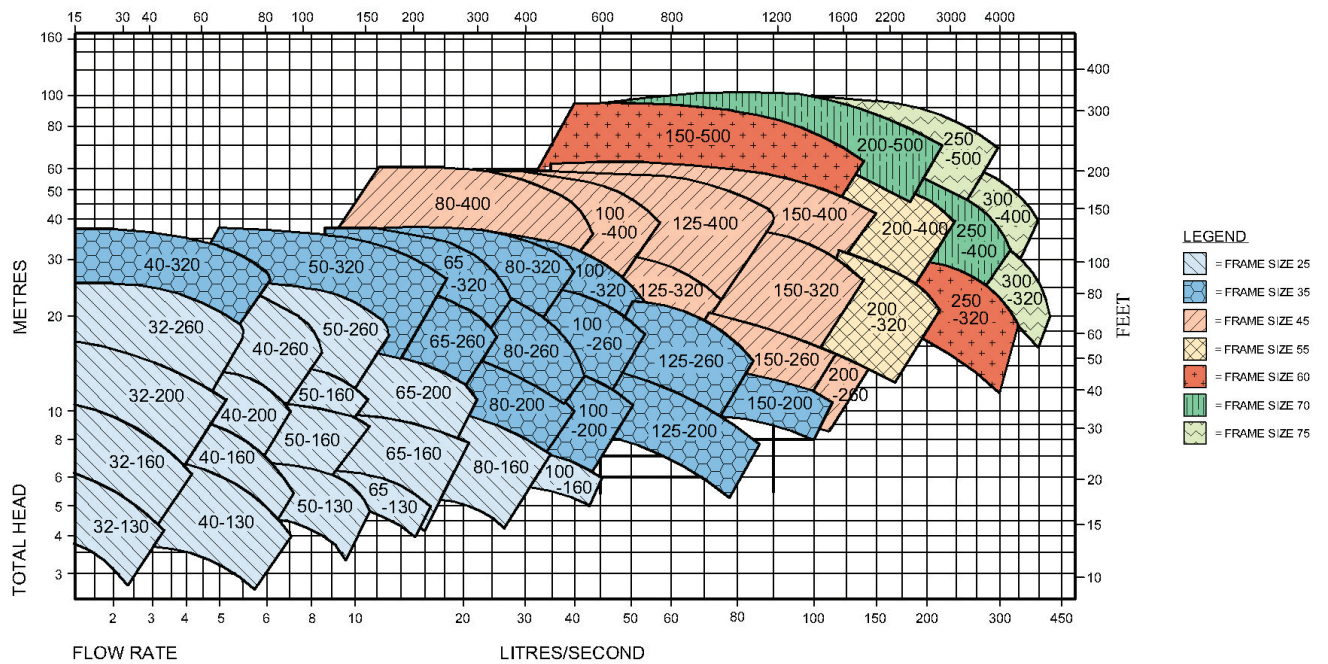

DISTRIBUTED BY

MALCOLM THOMPSON PUMPS

1800 733 687

www.mtp.com.au | mtp@mtp.com.au

For information on these products or for any specialised requirements please contact your local Aquaplus distributor or visit our website at www.aquapluspumps.com.au