

## Dimensions

### SDE Series

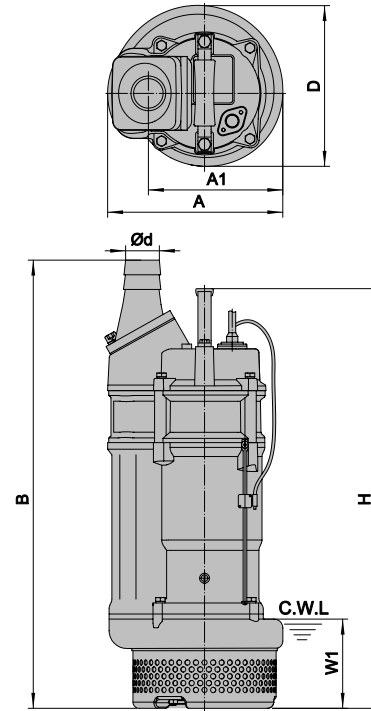
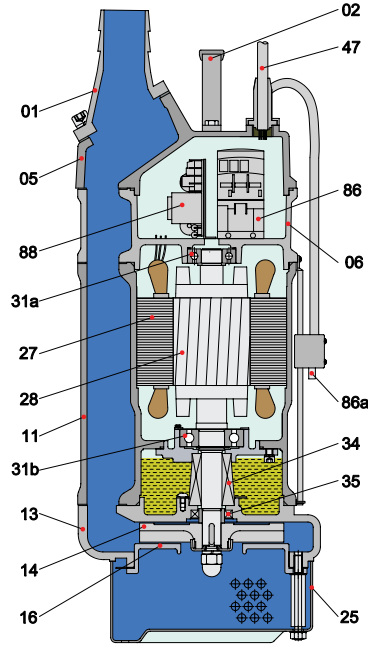

C.W.L.:Continuous running water level

Item No.	Part Name	Material	Item No.	Part Name	Material
01	Hose coupling	Cast Iron	28	Rotor	Shaft: AISI420SS
02	Handle	Rubber & Steel	31a	Bearing	Ball Bearing
05	Upper cover	Cast Iron	31b	Bearing	Ball Bearing
06	Upper Support	Cast Iron	34	Mechanical Seal	Sic-Sic/Carbon-Sic (≤2.2kW)
11	Motor body	Cast Iron			Sic-Sic/Sic-Sic (≥3.7kW)
13	Pump body	Cast Iron	35	Oil Seal	
14	Impeller	high Chrome Alloy	47	Cable	
16	Inlet Plate	Ductile Iron	86	AC Contractor	
25	Strainer	Steel	86a	Water Level Sensor	
27	Stator		88	Controller Block	

Model (50/60Hz)	d	A	A1	B	D	H	W1	N.W	G.W	Packing Dimension
	mm	mm	mm	mm	mm	mm	mm	Kg	Kg	mm
SDE-50-52-1.5T2-O	50	235	190	613	216	582	120	41	40	620x265x275
SDE-80-52-1.5T2-O	80	235	190	620	216	582	120	41	40	620x265x275
SDE-50-52-2.2T2-O	50	235	190	613	216	582	120	44	43	620x265x275
SDE-80-52-2.2T2-O	80	235	190	620	216	582	120	44	43	620x265x275
SDE-50-52-3.7T2-O	50	283	223	703	252	707	150	71	68	710x320x295
SDE-80-52-3.7T2-O	80	283	223	703	252	707	150	71	68	710x320x295
SDE-100-52-3.7T2-O	100	283	223	728	252	707	150	72	68	710x320x295
SDE-80-52-5.5T2-O	80	329	240	755	300	668	150	85.5	84	750x350x335
SDE-100-52-5.5T2-O	100	329	240	780	300	668	150	86.5	84	750x350x335