

## Dimensions

### SDS Series

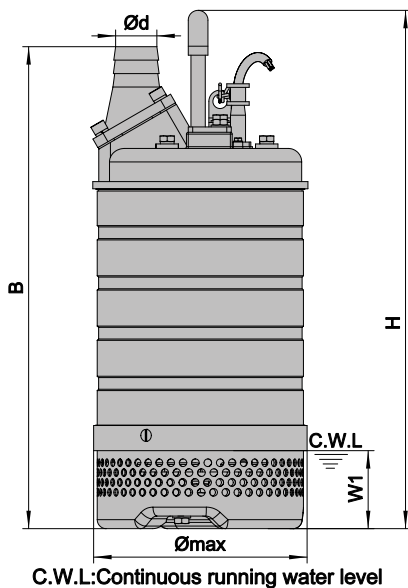
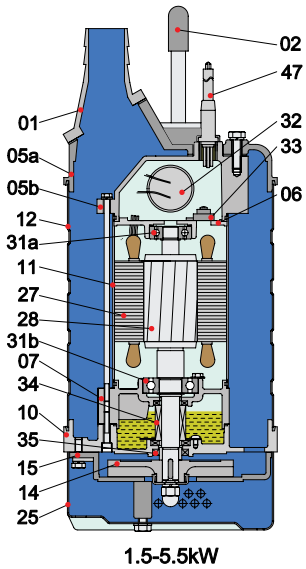
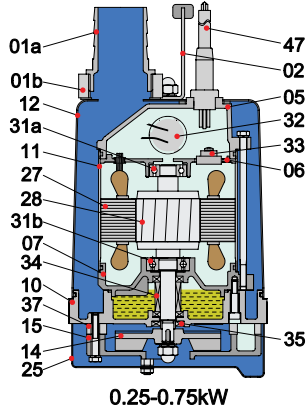

Item No.	Part Name	Material
01a	Hose Coupling	ABS
01b	Hose Coupling	PA66
02	Handle	Rubber & AISI304SS
05	Upper cover	Cast Iron
06	Up-Bearing House	Aluminum Die Casting
07	Bering House	Cast Iron
10	Seal House	Cast Iron
11	Motor Casing	Stainles Steel
12	Outer Casing	AISI304SS
14	Impeller	Ductile Iron
15	Diffuser	Cast Iron
25	Strainer	AISI304SS
27	Stator	
28	Rotor	Shaft: AISI304SS
31a	Bearing	Ball Bearing
31b	Bearing	Ball Bearing
32	Capacitor	
33	Motor Protector	
34	Mechanical Seal	Ceramic-Sic/Carbon Ceramic
35	Oil Seal	
37	Gasket	NBR
47	Cable	H07RN-F

Item No.	Part Name	Material
01	Hose Coupling	Cast Iron
02	Handle	Rubber & Steel
05a	Upper Cover	Cast Iron
05b	Upper Cover	Cast Iron
06	Up-Bearing House	Cast Iron
07	Bering House	Cast Iron
10	Seal Bracket	Cast Iron
11	Motor Casing	Stainless Steel
12	Outer Casing	Stainless Steel
14	Impeller	High Chrome Alloy
15	Diffuser	Ductile Iron
25	Strainer	Steel
27	Stator	
28	Rotor	Shaft: AISI420SS
31a	Bearing	Ball Bearing
31b	Bearing	Ball Bearing
32	Capacitor	(Single Phase Only)
33	Motor Protector	11kW
34	Mechanical Seal	Sic-Sic/Carbon-Sic(≤2.2kW) Sic-Sic/Sic-Sic(3.7-5.5kW)
35	Oil Seal	
47	Cable	H07RN-F

Model	H	B	Ømax	W1
SDS-50-52-.25M2-AP-O	345	342	184	50
SDS-50-52-.4M2-AP-O	345	342	184	50
SDS-50-52-.75M2-AP-O	365	362	184	50
SDS-50-52-1.5M2-AP-O	582	560	240	87
SDS-80-52-1.5M2-AP-O	582	567	240	87
SDS-50-52-1.5T2-O	563	540	240	87
SDS-80-52-1.5T2-O	563	547	240	87
SDS-50-52-2.2T2-O	563	540	240	87
SDS-80-52-2.2T2-O	563	547	240	87
SDS-50-52-1.5T2-AP-O	613	590	240	87
SDS-80-52-1.5T2-AP-O	613	597	240	87
SDS-50-52-2.2T2-AP-O	613	597	240	87
SDS-80-52-2.2T2-AP-O	613	597	240	87
SDS-50-52-3.7T2-O	515	591	300	76
SDS-80-52-3.7T2-O	515	591	300	76

Model	H	B	Ømax	W1
SDS-100-52-3.7T2-O	515	616	300	76
SDS-80-52-5.5T2-O	555	631	300	76
SDS-100-52-5.5T2-O	555	656	300	76
SDS-50-52-3.7T2-AP-O	565	641	300	76
SDS-80-52-3.7T2-AP-O	565	641	300	76
SDS-100-52-3.7T2-AP-O	565	666	300	76
SDS-80-52-5.5T2-AP-O	605	681	300	76
SDS-100-52-5.5T2-AP-O	605	706	300	76
SDS-80-52-7.5T2-O	700	810	355	142
SDS-100-52-7.5T2-O	700	810	355	142
SDS-100-52-11T2-O	745	855	355	142
SDS-150-52-11T2-O	745	855	355	142
SDS-100-52-15T2-O	768	882	355	142
SDS-150-52-15T2-O	768	882	355	142

B: The height from pump's bottom to outlet  
H: Th height from pump's bottom to handle top

AQUA0007