

Dimensions

SDVE Series

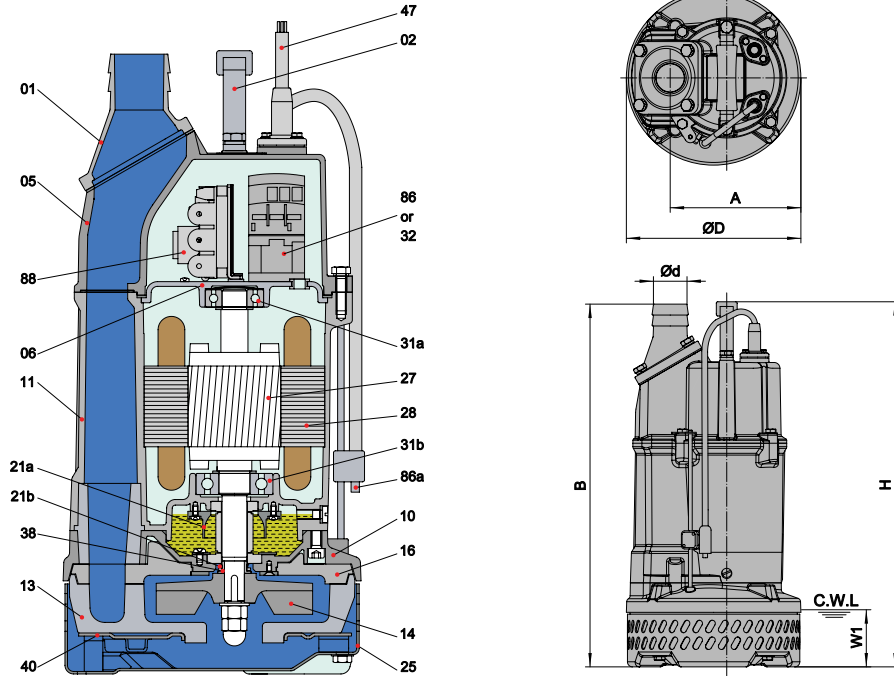

C.W.L.:Continuous running water level

Item No.	Part Name	Material	Item No.	Part Name	Material
01	Hose Coupling	Aluminum Die Casting	27	Stator	
02	Handle	Rubber & AISI304SS	28	Rotor	Shaft: Stainless Steel
05	Upper cover	Aluminum Die Casting	31a	Bearing	Ball Bearing
06	Up-bearing house	Cast Iron	31b	Bearing	Ball Bearing
10	Seal House	Aluminum Die Casting	32	Capacitor	
11	Motor Body	Aluminum Die Casting	34	Mechanical Seal	Sic-Sic/Carbin-Sic
13	Pump Body	NBR	38	Shaft Sleeve	
14	Impeller	Ductile Iron	40	Clamping Plate	Steel
		Optional: High Chrome Alloy	47	Cable	
16	Plate	NBR	86	AC Contactor	Only Three Phase
21a	Oil Riser	NBR	86a	Water Level Sensor	
21b	Sand Guard	PA66+GF30	88	Controller Block	

Model (50/60Hz)	d	A	B	D	H	W1	N.W	G.W	Packing Dimension
	mm	mm	mm	mm	mm	mm	Kg	Kg	mm
SDVE-50-60-1.5M2-V	50	178	515	240	515	80	26.5	31	570x270x285
SDVE-80-60-1.5M2-V	80	190	539	240	515	80	27	32	590x270x285
SDVE-50-60-1.5T2-V	50	178	515	240	515	80	24.5	29	570x270x285
SDVE-80-60-1.5T2-V	80	190	539	240	515	80	25	30	590x270x285
SDVE-50-60-2.2T2-V	50	178	515	240	515	80	27	31	570x270x285
SDVE-80-60-2.2T2-V	80	190	539	240	515	80	27.5	32.5	590x270x285